

PART: I-P1D

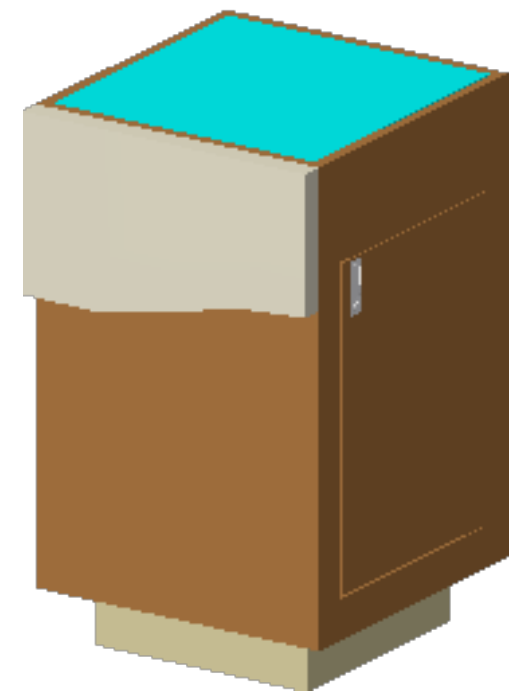

3D VIEW
RIGHT VIEW

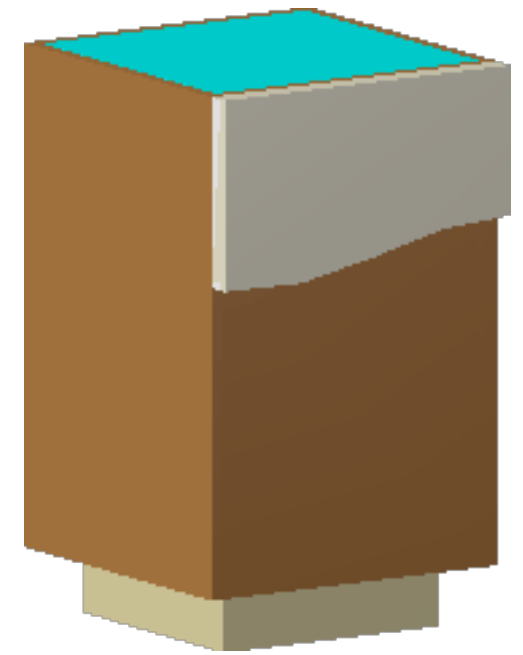

3D VIEW
LEFT VIEW

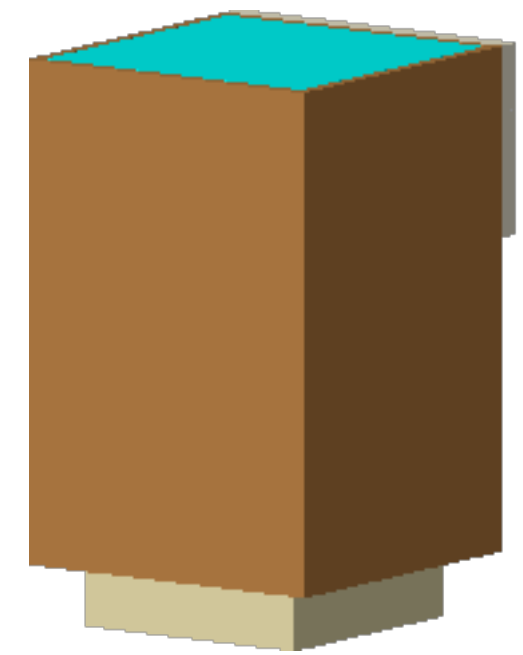

3D VIEW
BACK VIEW

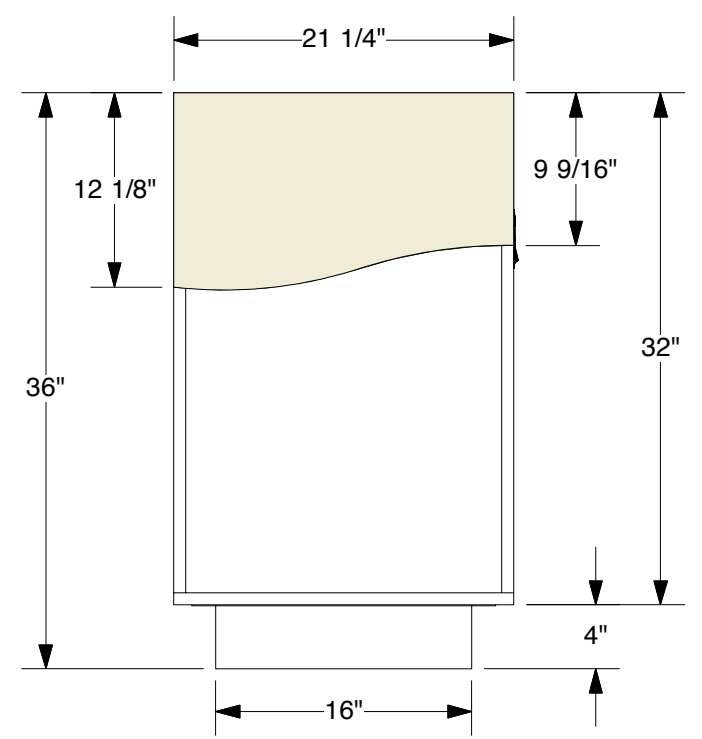

FRONT VIEW

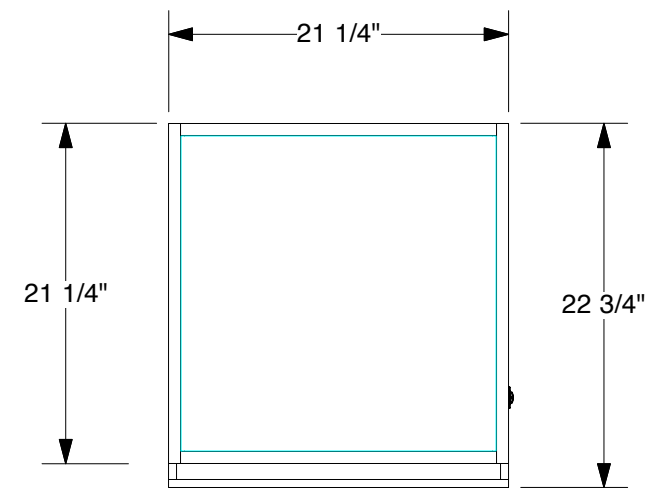

PLAN VIEW

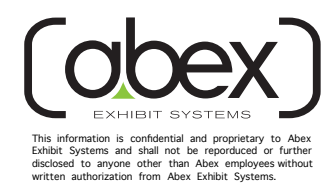

Revisions				Description	Date	Scale	Engineer
Zone	Rev.	Description	Date				
				ICON:21-1/4"W UPLIT & WAVE ACCENT PANEL	10/7/2019	n/a	AS
				Part #			QC Approval:
				I-P1D		ICON	00
							Production Approval: