

PART: I-P2D

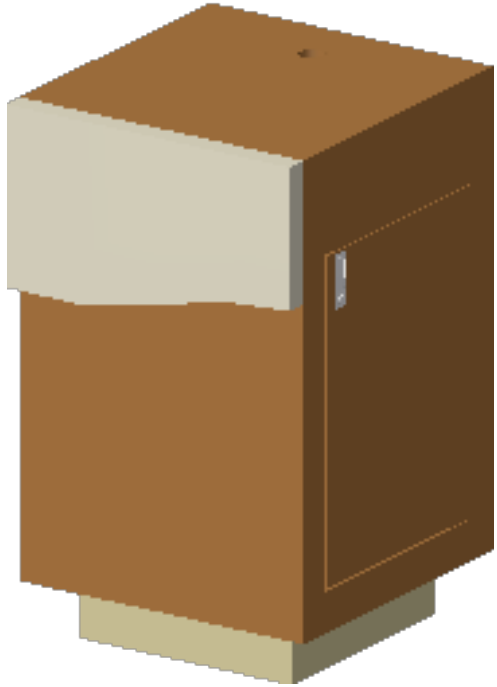

3D VIEW
RIGHT VIEW

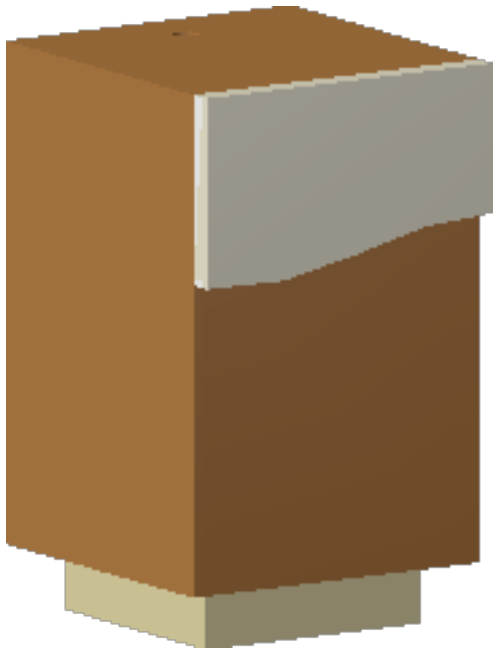

3D VIEW
LEFT VIEW

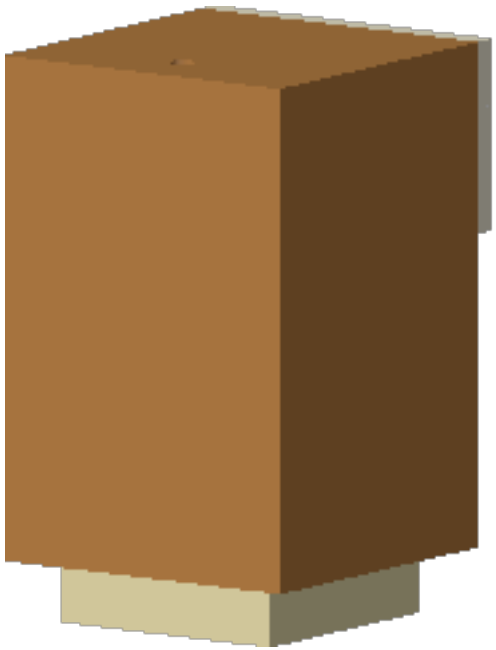

3D VIEW
BACK VIEW

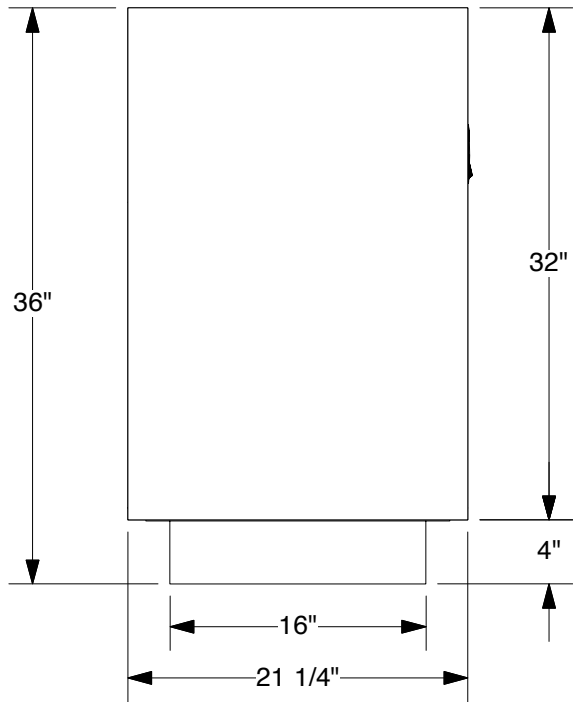

FRONT VIEW

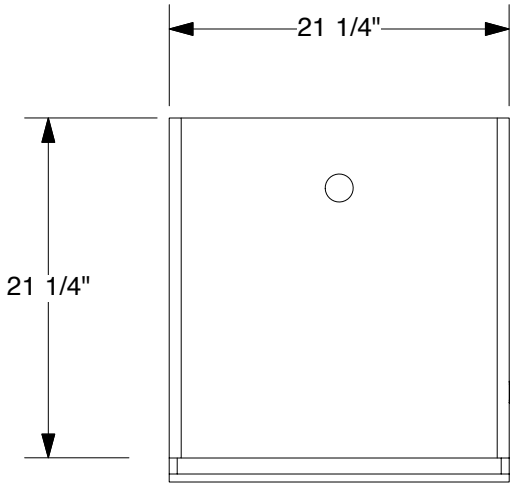

PLAN VIEW



This information is confidential and proprietary to Abex Exhibit Systems and shall not be reproduced or further disclosed to anyone other than Abex employees without written authorization from Abex Exhibit Systems.

Revisions				Description	Date	Scale	Engineer
Zone	Rev.	Description	Date				
				ICON: 21-1/4"W DOWNLIT & WAVE ACCENT PANEL	10/7/2019	n/a	AS
				Part #			QC Approval:
				I-P2D		ICON	00
							Production Approval: